



Impact Bars

- Unique abrasion and impact resistant qualities of Linatex natural rubber
- Excellent energy absorption
- Low friction surface coating
- Cost-effective and easy to fit
- Radiused top edges preventing damage to belts
- 2 capping thickness available for extended wear
- Cradles available to suit all standard conveyor widths



Linatex Impact Bars

Linatex Impact Bars are made from unique abrasion and impact resistant 60 shore natural rubber.

The rubber compound provides excellent cushioning and impact absorption. The 6mm or 12mm thick, low friction UHMWPE top layer, provides a protective surface preventing wear and damage. Easily installed, using M16 bolts, the metal channel running the length of each impact bar enables easy fixing and removal.

Linatex Impact Bars are available in two thicknesses – 55mm and 75mm, by 1,240mm long. They are fitted with a standard aluminium insert for simple installation. Length can be cut to suit shorter requirements.

Applications

- Conveyor support, feed and loading points
 - Impact Beds
 - Feed chute collectors

Benefits

- Excellent energy absorption of Linatex rubber compound
 - Extended life
- Protective top surface provides low friction, preventing damage and reducing wear
- Angled leading edges prevent bolt and belt damage



Impact Bar cradle assembly

Technical specification

Colour : Black

Hardness of rubber : 60 Shore

Bolt diameter : 16mm Coach bolts (available on request)

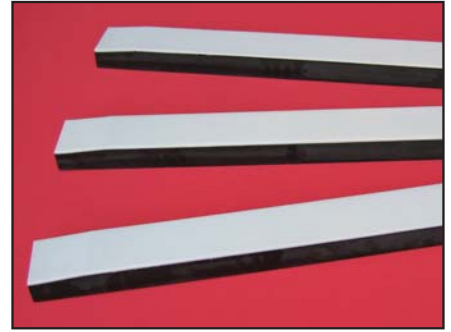

Part Number	Width	Thickness	Length	Capping Thickness
LML1223-504-1240	100 mm	55 mm	1,240 mm	6 mm
LML1225-504-1240	100 mm	75 mm	1,240 mm	6 mm
LML1224-504-1240	100 mm	55 mm	1,240 mm	12 mm
LML1226-504-1240	100 mm	75 mm	1,240 mm	12 mm

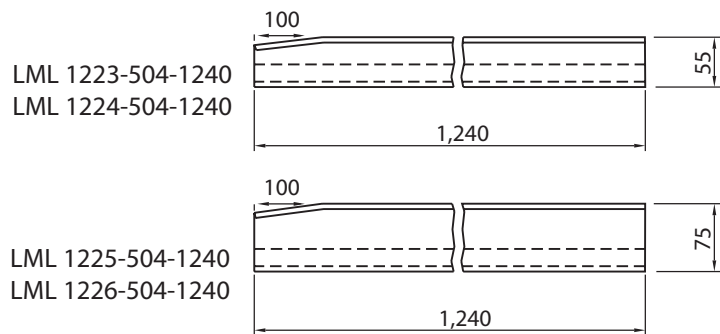
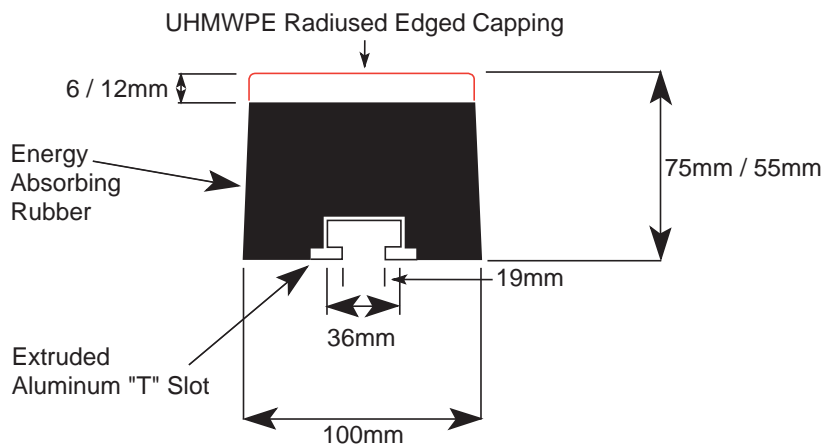

Linatex is a rubber manufacturer, acknowledged around the world as the foremost authority in the use of abrasive and impact resistant rubbers. Through continued innovation and product development, the Linatex Group has an unrivalled depth of knowledge and experience in this field.

LINATEX

Technical specification

Colour : Black

Hardness of rubber : 60 Shore

Bolt diameter : 16mm Coach bolts (available on request)



Part Number	Width	Thickness	Length	Capping Thickness
LML1223-504-1240	100 mm	55 mm	1,240 mm	6 mm
LML1225-504-1240	100 mm	75 mm	1,240 mm	6 mm
LML1224-504-1240	100 mm	55 mm	1,240 mm	12 mm
LML1226-504-1240	100 mm	75 mm	1,240 mm	12 mm

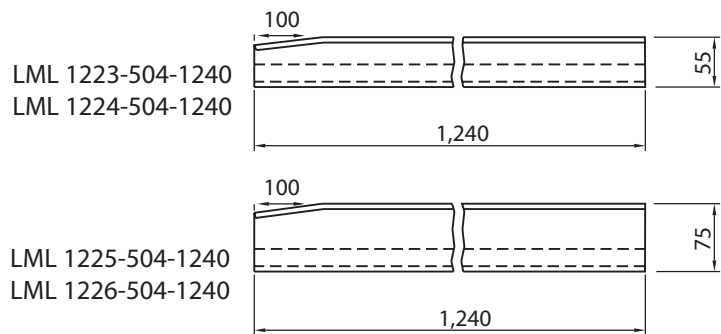
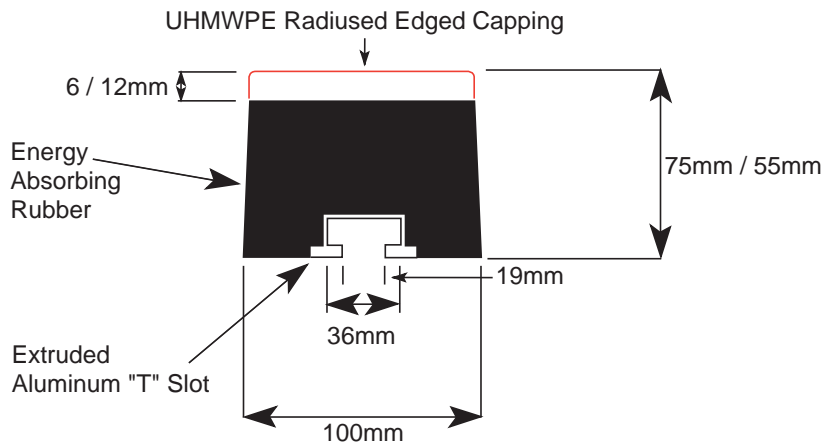

Linatex is a rubber manufacturer, acknowledged around the world as the foremost authority in the use of abrasive and impact resistant rubbers. Through continued innovation and product development, the Linatex Group has an unrivalled depth of knowledge and experience in this field.

